



US 20160372045A1

(19) **United States**

(12) **Patent Application Publication**
Hwang

(10) **Pub. No.: US 2016/0372045 A1**

(43) **Pub. Date: Dec. 22, 2016**

(54) **ORGANIC LIGHT EMITTING DISPLAY**

(52) **U.S. Cl.**

(71) Applicant: **SAMSUNG DISPLAY CO., LTD.**,
Yongin-si (KR)

CPC **G09G 3/3258** (2013.01); **G09G 2330/00**
(2013.01); **G09G 2300/0452** (2013.01); **G09G**
2300/0426 (2013.01); **G09G 2320/0233**
(2013.01); **H01L 27/3279** (2013.01)

(72) Inventor: **Young-In Hwang**, Yongin-city (KR)

(21) Appl. No.: **15/253,395**

(57) **ABSTRACT**

(22) Filed: **Aug. 31, 2016**

Related U.S. Application Data

(63) Continuation of application No. 12/953,343, filed on
Nov. 23, 2010, now abandoned.

An organic light emitting display is capable of reducing
variation in power transmitted to pixels to reduce or prevent
non-uniformity of brightness from being generated. The
organic light emitting display includes a pixel including a
red sub pixel, a green sub pixel, and a blue sub pixel and first
pixel power source lines for supplying a first pixel power
from a first pixel power source to the red sub pixel, the green
sub pixel, and the blue sub pixel, wherein the first pixel
power source lines coupled to at least two different color sub
pixels of the red, green and blue sub pixels have different
widths. The first pixel power source lines have widths that
may correspond to a voltage drop of the first pixel power
source or may correspond to deterioration of the respective
sub pixels to which they are coupled.

(30) **Foreign Application Priority Data**

Apr. 29, 2010 (KR) 10-2010-0040043

Publication Classification

(51) **Int. Cl.**
G09G 3/3258 (2006.01)

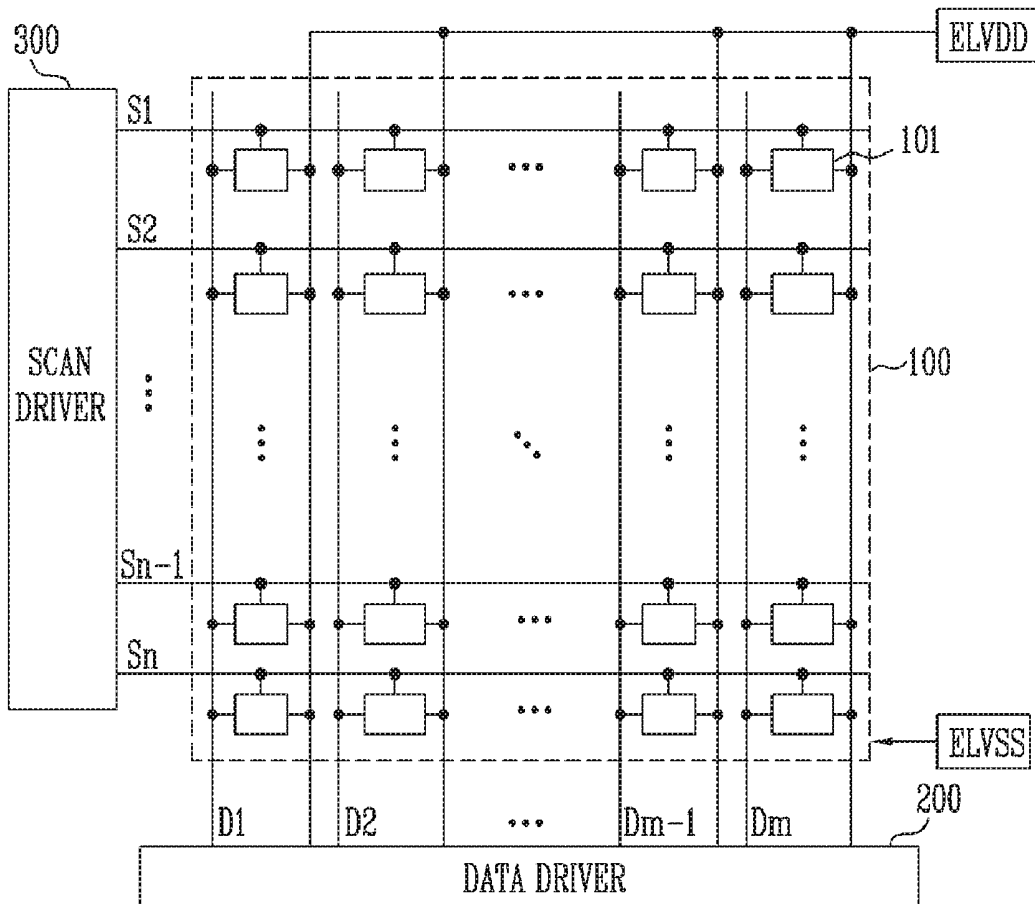

FIG. 1
(RELATED ART)

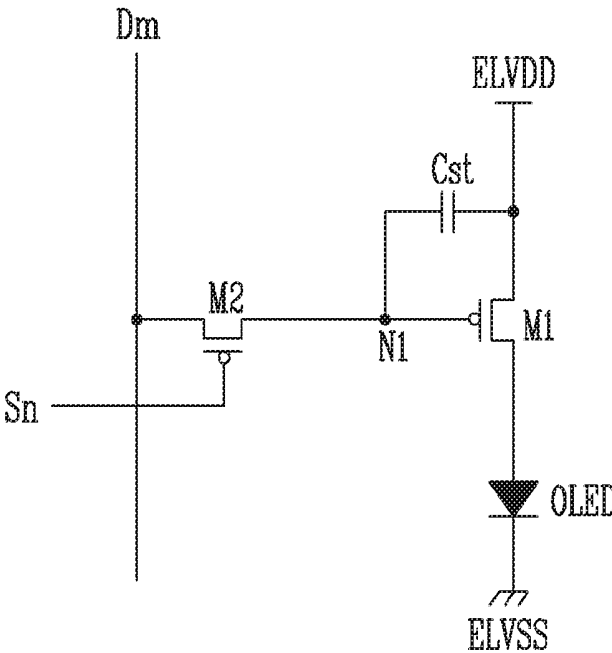

FIG. 2

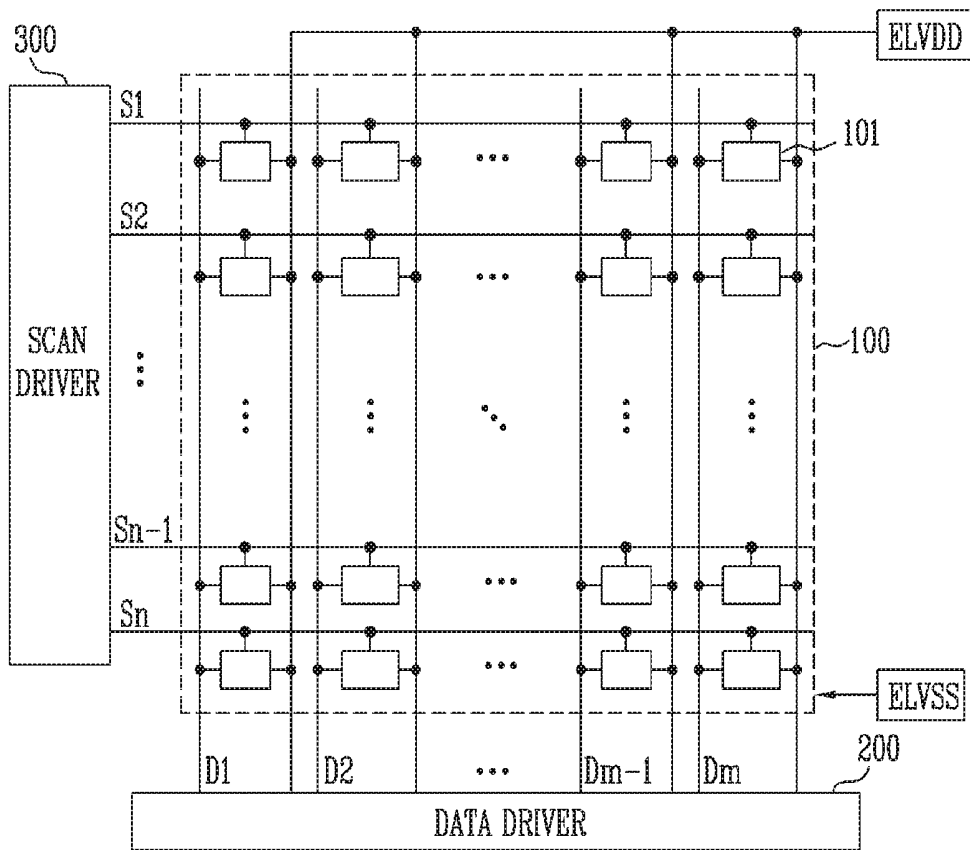

FIG. 3A

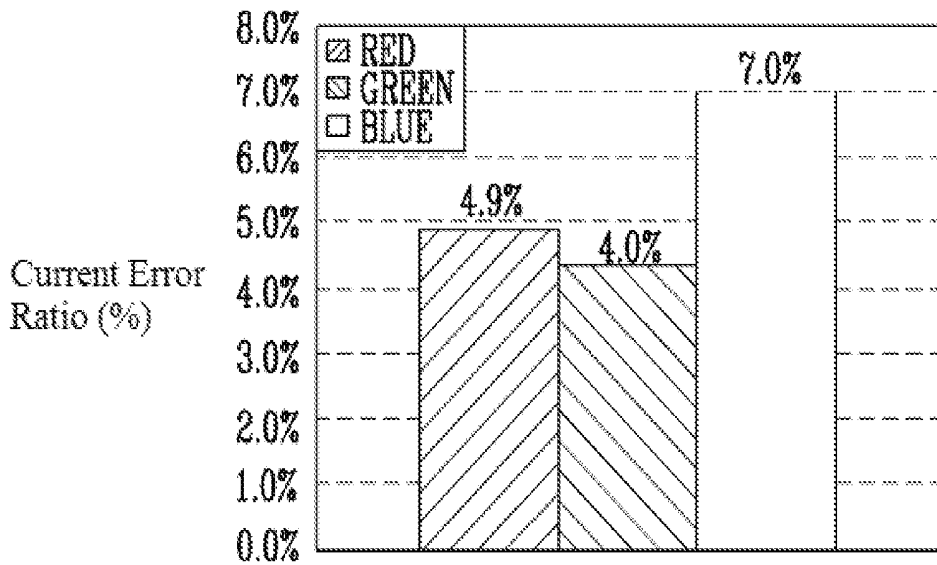

FIG. 3B

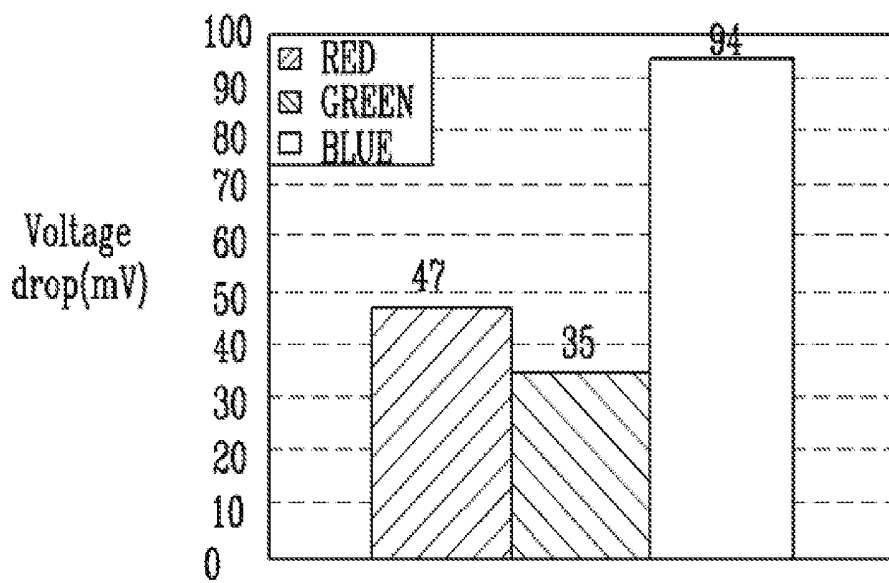
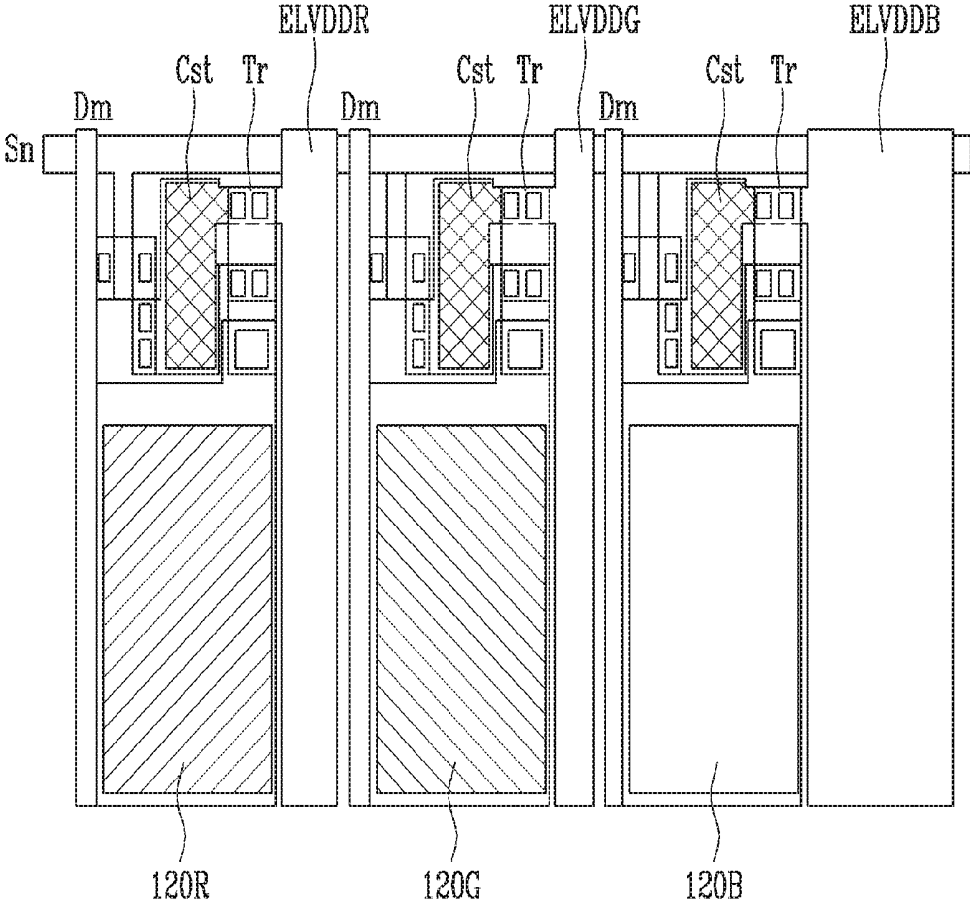

FIG. 4



ORGANIC LIGHT EMITTING DISPLAY

CROSS-REFERENCE TO RELATED APPLICATION

[0001] This application is a continuation of U.S. patent application Ser. No. 12/953,343, filed Nov. 23, 2010, which claims priority to and the benefit of Korean Patent Application No. 10-2010-0040043, filed on Apr. 29, 2010, in the Korean Intellectual Property Office, the entire content of which is incorporated herein by reference.

BACKGROUND

[0002] 1. Field

[0003] An embodiment of the present invention relates to an organic light emitting display.

[0004] 2. Description of Related Art

[0005] Recently, various flat panel displays (FPDs) capable of reducing weight and volume, which are disadvantages of cathode ray tubes (CRTs), have been developed. The FPDs include liquid crystal displays (LCDs), field emission displays (FEDs), plasma display panels (PDPs), and organic light emitting displays.

[0006] Among the FPDs, the organic light emitting display displays an image using organic light emitting diodes (OLEDs) that generate light by the recombination of electrons and holes.

[0007] The organic light emitting displays are being widely applied in personal digital assistants (PDAs), MP3 players, and mobile telephones due to advantages such as excellent color reproducibility and reduced thickness.

[0008] FIG. 1 is a circuit diagram illustrating a pixel of an organic light emitting display. Referring to FIG. 1, the pixel is coupled to a data line Dm, a scan line Sn, and a pixel power source line coupled to a pixel power source ELVDD and includes a first transistor M1, a second transistor M2, a capacitor Cst, and an organic light emitting diode OLED.

[0009] In the first transistor M1, a source is coupled to the pixel power source line ELVDD, a drain is coupled to the OLED, and a gate is coupled to a first node N1. In the second transistor M2, a source is coupled to the data line Dm, a drain is coupled to the first node N1, and a gate is coupled to the scan line Sn. The capacitor Cst is coupled between the first node N1 and the pixel power source ELVDD to maintain a voltage between the first node N1 and the pixel power source ELVDD for an amount of time (e.g., a predetermined time). The OLED includes an anode electrode, a cathode electrode, and a light emitting layer. In the OLED, the anode electrode is coupled to the drain of the first transistor M1 and the cathode electrode is coupled to a low potential power source ELVSS, so that when current flows from the anode electrode to the cathode electrode, the light emitting layer emits light, and brightness is controlled corresponding to the amount of current.

[0010] In the pixel having the above structure, current corresponding to EQUATION 1 flows to the OLED.

$$I_d = \frac{\beta}{2}(V_{gs} - V_{th})^2 = \frac{\beta}{2}(ELVdd - V_{data} - V_{th})^2 \quad \text{EQUATION 1}$$

wherein, I_d , V_{gs} , V_{th} , $ELVdd$, V_{data} , and β represent current that flows to the OLED, a voltage between the gate and source of the first transistor, a threshold voltage of the

first transistor, a voltage of the pixel power source, a voltage of the data signal, and a constant, respectively.

[0011] Since the current that flows to the OLED is as represented by EQUATION 1, when the voltage of the pixel power source ELVDD changes, the amount of current that flows also changes.

[0012] Therefore, since a magnitude of internal resistance of the pixel power source line to which the pixel power source ELVDD is coupled varies with a distance of the pixel from the pixel power source ELVDD, a difference in brightness between pixels may be generated.

SUMMARY

[0013] Accordingly, embodiments of the present invention have been made to provide an organic light emitting display capable of reducing variations in power transmitted to pixels to reduce or prevent non-uniformity of pixel brightness.

[0014] In order to achieve the foregoing and/or other aspects of the present invention, according to a first aspect of the present invention, there is provided an organic light emitting display including a pixel including a red sub pixel, a green sub pixel, and a blue sub pixel and first pixel power source lines for supplying a first pixel power from a first pixel power source to the red sub pixel, the green sub pixel, and the blue sub pixel, wherein the first pixel power source lines coupled to at least two different color sub pixels of the red, green and blue sub pixels have different widths.

[0015] The widths of the first pixel power source lines may correspond to a voltage drop of the first pixel power source.

[0016] The widths of the first pixel power source lines may correspond to deterioration of the respective sub pixels to which they are coupled.

[0017] The first pixel power source lines coupled to the blue sub pixels may have a largest width among the first pixel power source lines.

[0018] The organic light emitting display may further include a data driver for transmitting data signals to the pixel and a scan driver for transmitting scan signals to the pixel.

[0019] The first pixel power source lines coupled to the green sub pixels may have a smallest width among the first pixel power source lines.

[0020] The first pixel power source lines may include a first main pixel power source line electrically coupled to a first sub pixel power source line.

[0021] In the organic light emitting display according to embodiments of the present invention, variation in the power transmitted to pixels is reduced to reduce or prevent non-uniformity of pixel brightness. In addition, a change in an aperture ratio is reduced, making it possible to reduce or prevent brightness deterioration.

BRIEF DESCRIPTION OF THE DRAWINGS

[0022] The accompanying drawings, together with the specification, illustrate exemplary embodiments of the present invention, and, together with the description, serve to explain the principles of embodiments of the present invention, wherein:

[0023] FIG. 1 is a circuit diagram illustrating a pixel of an organic light emitting display;

[0024] FIG. 2 is a schematic diagram illustrating an organic light emitting display according to an embodiment of the present invention;

[0025] FIG. 3A is a graph illustrating the current error ratios of a red sub pixel, a green sub pixel, and a blue sub pixel, which are caused by the internal resistance of first pixel power source lines;

[0026] FIG. 3B is a graph illustrating the voltage drops of the red sub pixel, the green sub pixel, and the blue sub pixel, which are caused by the internal resistance of the first pixel power source lines; and

[0027] FIG. 4 is a layout diagram illustrating the pixel of the embodiment shown in FIG. 2.

DETAILED DESCRIPTION

[0028] In the following detailed description, only certain exemplary embodiments of the present invention have been shown and described, simply by way of illustration.

[0029] As those skilled in the art would realize, the described embodiments may be modified in various different ways, all without departing from the spirit or scope of the present invention. Accordingly, the drawings and description are to be regarded as illustrative in nature and not restrictive. In addition, when an element is referred to as being “on” another element, it can be directly on the element or be indirectly on the element with one or more intervening elements interposed therebetween. Also, when an element is referred to as being “connected to” or “coupled to” another element, it can be directly connected to the element or be indirectly connected to the element with one or more intervening elements interposed therebetween. Hereinafter, like reference numerals refer to like elements.

[0030] Hereinafter, embodiments of the present invention will be described as follows with reference to the attached drawings.

[0031] FIG. 2 is a schematic diagram illustrating an organic light emitting display according to an embodiment of the present invention. FIG. 3A is a graph illustrating current error ratios of a red sub pixel, a green sub pixel, and a blue sub pixel, which are caused by internal resistance of first pixel power source lines. FIG. 3B is a graph illustrating voltage drops of the red sub pixel, the green sub pixel, and the blue sub pixel, which are caused by the internal resistance of the first pixel power source lines.

[0032] Referring to FIG. 2, the organic light emitting display includes a display unit 100, a data driver 200, and a scan driver 300. The display unit 100 includes a plurality of data lines D1, D2, . . . , Dm-1, and Dm, a plurality of scan lines S1, S2, . . . , Sn-1, and Sn, and a plurality of pixels 101 formed in regions defined by the plurality of data lines D1, D2, . . . , Dm-1, and Dm and the n scan lines S1, S2, . . . , Sn-1, and Sn. In addition, each of the pixels 101 receives power from a first pixel power source ELVDD and a second pixel power source ELVSS to be driven. At this time, the power from the first pixel power source ELVDD is received (e.g., commonly received) through a plurality of first pixel power source lines and the power from the second pixel power source ELVSS is received (e.g., commonly received) through an electrode deposited on the front surface of the display unit.

[0033] Each pixel 101 includes a red sub pixel, a green sub pixel, and a blue sub pixel. In addition, each of the sub pixels includes a pixel circuit and an organic light emitting diode (OLED), and generates pixel current that flows from the pixel circuit to the pixel corresponding to data signals transmitted through the plurality of data lines D1, D2, . . . , Dm-1, and Dm and scan signals transmitted through the

plurality of scan lines S1, S2, . . . , Sn-1, and Sn, so that the pixel current flows to the OLED.

[0034] At this time, as illustrated in FIGS. 3A and 3B, the current error ratios and the voltage drops of a red sub pixel, a green sub pixel, and a blue sub pixel, which are caused by the internal resistance of the first pixel power source lines being different from each other, are shown. For example, the current error ratio of the blue sub pixel is 7%, the current error ratio of the red sub pixel is 4.9%, and the current error ratio of the green sub pixel is 4.4%. In addition, the voltage drop of the green sub pixel is 94 mV, the voltage drop of the red sub pixel is 47 mV, and the voltage drop of the green sub pixel is 35 mV. The current error ratio and voltage drop of the blue sub pixel are larger than the current error ratios and voltage drops of the red sub pixel and the green sub pixel. Therefore, the non-uniformity of brightness of the blue sub pixel is larger than the non-uniformity of brightness of the other two sub pixels. A width of the first pixel power source lines may be increased to reduce the current error ratios and voltage drops of the first pixel power source lines. However, when the width of the first pixel power source lines is increased as if all of the first pixel power source lines are coupled to blue sub pixels, the widths of the first pixel power source lines coupled to red sub pixels and green sub pixels are unnecessarily large, and an aperture ratio is reduced.

[0035] Therefore, according to an embodiment of the present invention, widths of the first pixel power source lines of the sub pixels vary. That is, the thicknesses (or widths) of the first pixel power source lines coupled to the red sub pixel, the green sub pixel, and the blue sub pixel vary (e.g., are independently set) so that the width of the first pixel power source line coupled to the red sub pixel is determined in accordance with the voltage drop and current error ratio of the red sub pixel, and the width of the first pixel power source line coupled to the green sub pixel is determined in accordance with the voltage drop and current error ratio of the green sub pixel. In addition, the width of the first pixel power source line coupled to the blue sub pixel is determined in accordance with the voltage drop and current error ratio of the blue sub pixel.

[0036] The data driver 200 is coupled to the m data lines D1, D2, . . . , Dm-1, and Dm and generates data signals to sequentially transmit the data signals row-by-row to the m data lines D1, D2, . . . , Dm-1, and Dm (e.g., to the data lines one row at a time).

[0037] The scan driver 300 is coupled to the n scan lines S1, S2, . . . , Sn-1, and Sn and generates scan signals to transmit the scan signals to the n scan lines S1, S2, . . . , Sn-1, and Sn. A specific row (e.g., a specific scan line) is selected by the scan signals and the data signals are transmitted to the pixels 101 positioned in the selected row so that currents corresponding to the data signals are generated in the pixels.

[0038] FIG. 4 is a layout diagram illustrating the pixel of the embodiment shown in FIG. 2. Referring to FIG. 4, the pixel includes a red sub pixel 120R, a green sub pixel 120G, and a blue sub pixel 120B.

[0039] Each of the red sub pixel 120R, the green sub pixel 120G, and the blue sub pixel 120B includes a transistor Tr and a storage capacitor Cst. The red sub pixel 120R, the green sub pixel 120G, and the blue sub pixel 120B are coupled to the scan line Sn and the data line Dm, and are coupled to first pixel power source lines, e.g., a first pixel power source line ELVDD for supplying the first pixel

power source ELVDD to the red sub pixel **120R**, a first pixel power source line ELVDDG for supplying the first pixel power source ELVDD to the green sub pixel **120G**, and a first pixel power source line ELVDDDB for supplying the first pixel power source ELVDD to the blue sub pixel **120B**.

[0040] At this time, as illustrated in FIGS. 3A and 3B, since the voltage drop and the current error rate generated by the first pixel power source line ELVDDDB coupled to the blue sub pixel **120B** are largest, and since the voltage drop and the current error rate generated by the first pixel power source line ELVDDG coupled to the green sub pixel **120G** are smallest, the width of the first pixel power source line ELVDDDB coupled to the blue sub pixel **120B** is largest, and the width of the first pixel power source line ELVDDG coupled to the green sub pixel **120G** is smallest.

[0041] As described above, when the width of the first pixel power source lines is determined in accordance with the voltage drops and current error ratios of the respective sub pixels to which the first pixel power source lines are coupled, the sum of the widths of all of the first pixel power source lines is smaller than if the width of all of the first pixel power source lines were determined in accordance with only the sub pixel whose efficiency is lowest.

[0042] While the present invention has been described in connection with certain exemplary embodiments, it is to be understood that the invention is not limited to the disclosed embodiments, but, on the contrary, is intended to cover various modifications and equivalent arrangements included within the spirit and scope of the appended claims, and equivalents thereof.

1.-9. (canceled)

10. An organic light emitting display comprising:
a plurality of pixels, each of the pixels comprising a blue sub pixel and a red sub pixel; and
a plurality of power source lines coupled to the blue and red sub pixels,
wherein the power source lines coupled to the blue sub pixels have a larger width than the power source lines coupled to the red sub pixels.

11. The organic light emitting display as claimed in claim 10, wherein the widths of the power source lines are in accordance with voltage drop of a power source supplied to the blue and red sub pixels.

12. The organic light emitting display as claimed in claim 10, wherein the widths of the power source lines correspond to deterioration of the respective sub pixels to which they are coupled.

13. The organic light emitting display as claimed in claim 10, wherein each of the pixels further comprises a green sub pixel.

14. The organic light emitting display as claimed in claim 10, further comprising:

a data driver for transmitting data signals to the pixels;
and

a scan driver for transmitting scan signals to the pixels.

15. An organic light emitting display comprising:
a plurality of pixels, each of the pixels comprising a blue sub pixel and a green sub pixel; and
a plurality of power source lines coupled to the blue and green sub pixels,

wherein the power source lines coupled to the blue sub pixels have a larger width than the power source lines coupled to the green sub pixels.

16. The organic light emitting display as claimed in claim 15, wherein the widths of the power source lines are in accordance with voltage drop of a power source supplied to the blue and green sub pixels.

17. The organic light emitting display as claimed in claim 15, wherein the widths of the power source lines correspond to deterioration of the respective sub pixels to which they are coupled.

18. The organic light emitting display as claimed in claim 15, further comprising:

a data driver for transmitting data signals to the pixels;
and

a scan driver for transmitting scan signals to the pixels.

19. An organic light emitting display comprising:
a plurality of pixels, each of the pixels comprising a blue sub pixel, a red sub pixel, and a green sub pixel; and
a plurality of power source lines coupled to the blue, red, and green sub pixels, respectively,
wherein the power source lines coupled to the blue sub pixels have a largest width among the power source lines.

20. The organic light emitting display as claimed in claim 19, wherein the widths of the power source lines are in accordance with voltage drop of a power source supplied to the blue, red, and green sub pixels.

21. The organic light emitting display as claimed in claim 19, wherein the widths of the power source lines correspond to deterioration of the respective sub pixels to which they are coupled.

22. The organic light emitting display as claimed in claim 19, wherein the widths of the power source lines are in accordance with current error ratios for the blue, red, and green sub pixels.

23. The organic light emitting display as claimed in claim 19, wherein the power source lines coupled to the green sub pixels have a smallest width from among the power source lines.

24. The organic light emitting display as claimed in claim 19, further comprising:

a data driver for transmitting data signals to the pixels;
and

a scan driver for transmitting scan signals to the pixels.

* * * * *

| | | | |
|----------------|---|---------|------------|
| 专利名称(译) | 有机发光显示器 | | |
| 公开(公告)号 | US20160372045A1 | 公开(公告)日 | 2016-12-22 |
| 申请号 | US15/253395 | 申请日 | 2016-08-31 |
| [标]申请(专利权)人(译) | 三星显示有限公司 | | |
| 申请(专利权)人(译) | 三星DISPLAY CO., LTD. | | |
| 当前申请(专利权)人(译) | 三星DISPLAY CO., LTD. | | |
| [标]发明人 | HWANG YOUNG IN | | |
| 发明人 | HWANG, YOUNG-IN | | |
| IPC分类号 | G09G3/3258 | | |
| CPC分类号 | G09G3/3258 G09G2330/00 G09G2300/0452 H01L27/3211 G09G2320/0233 H01L27/3279 G09G2300/0426 G09G3/3208 G09G2300/0465 G09G2320/0223 G09G2320/0242 G09G2320/045 G09G2320/0666 G09G2330/02 H01L27/3246 H01L27/326 | | |
| 优先权 | 1020100040043 2010-04-29 KR | | |
| 其他公开文献 | US10290259 | | |
| 外部链接 | Espacenet USPTO | | |

摘要(译)

有机发光显示器能够减少传输到像素的功率的变化，以减少或防止产生亮度的不均匀性。有机发光显示器包括：像素，包括红色子像素，绿色子像素和蓝色子像素；以及第一像素电源线，用于从第一像素电源向红色子像素提供第一像素功率，绿色子像素和蓝色子像素，其中耦合到红色，绿色和蓝色子像素的至少两个不同颜色子像素的第一像素电源线具有不同的宽度。第一像素电源线具有可以对应于第一像素电源的电压降的宽度，或者可以对应于它们耦合到的各个子像素的劣化。

